

## EST-1011DT/DTH series of Air Conduit Temperature Transmitter

### Dimensions

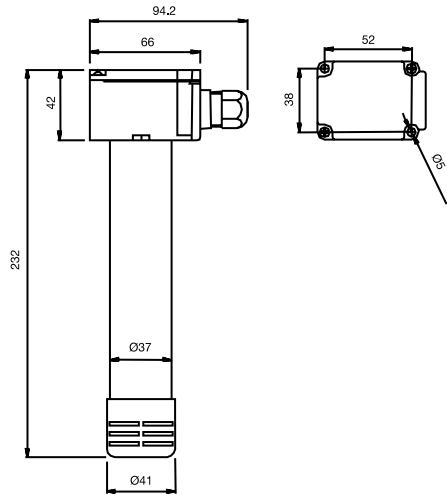

### Wiring diagram

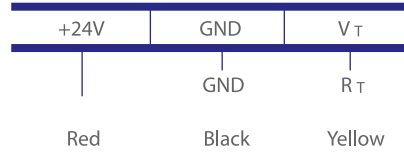

## EST1011-RT/RTH series of Temperature Transmitter & Temperature-Humidity Transmitter

### Dimensions

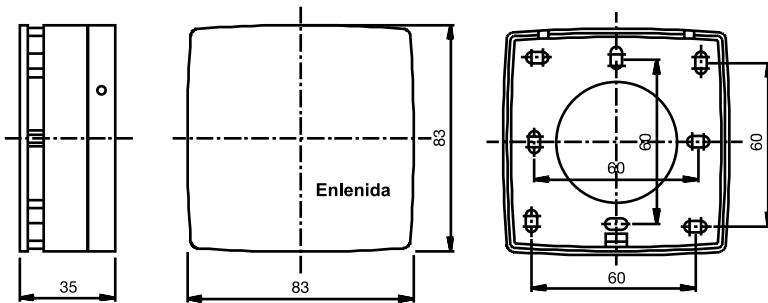

### EST1011-RT Wiring diagram



### EST1011-RTH Wiring diagram



## EST1011-PTA/B series of Water Pipe Temperature Transmitter

### Dimensions

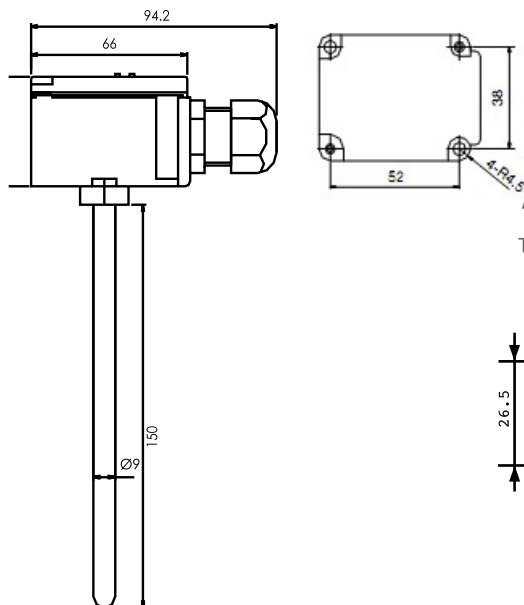

### Wiring diagram



Accessory (EST1011-PT/H55, H115 casing pipe)

There are two types of casing pipes, 55mm and 115mm

