

EFCT series of Fan Coil Thermostats

EFCT-501/501C

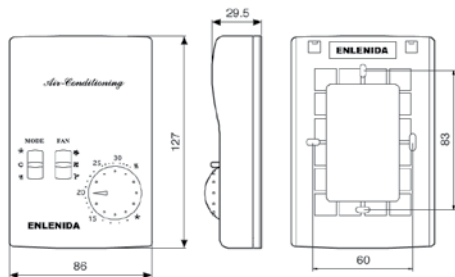

EFCT-502/502C

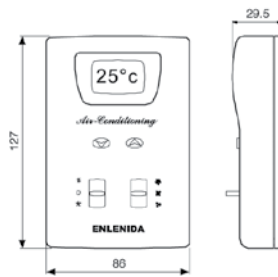

EFCT-503/503C

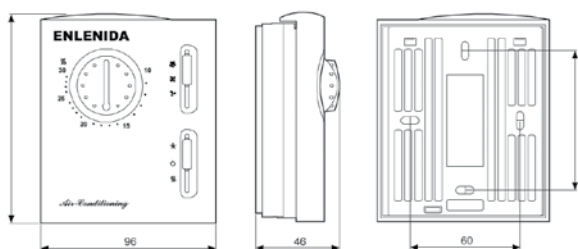

EFCT-504/504C

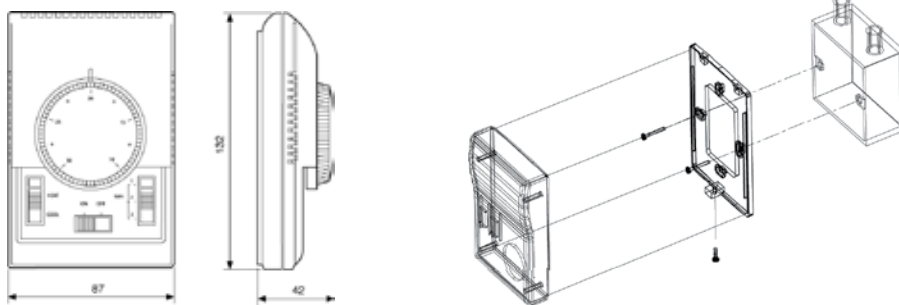

EFCT-506/506C

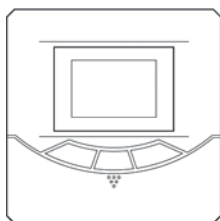

Two pipe system

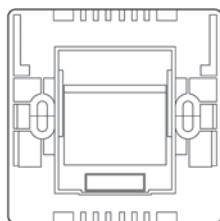

Four pipe system

EFCT-505/507/508
EFCT-505C/507C/508C

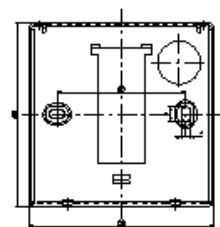

EFCT-501/502/503/501C/ 502C/503C wiring diagram

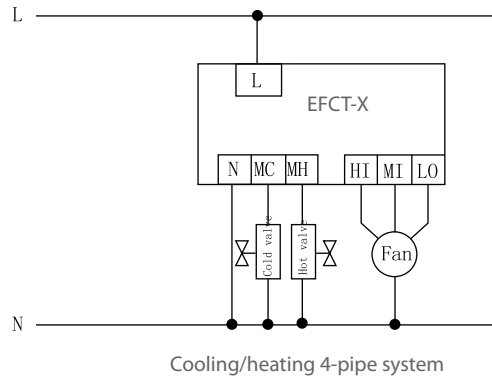
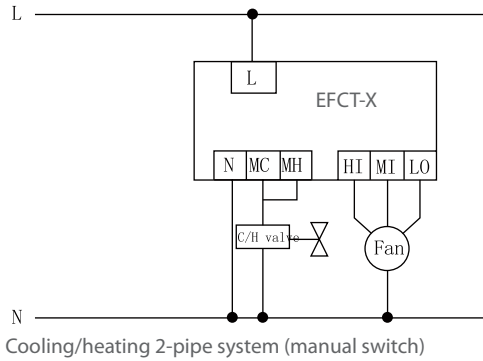

EFCT-504 wiring diagram

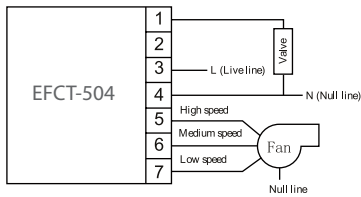

EFCT-504 Cooling/heating 2 or 4-pipe system

EFCT-506 wiring diagram

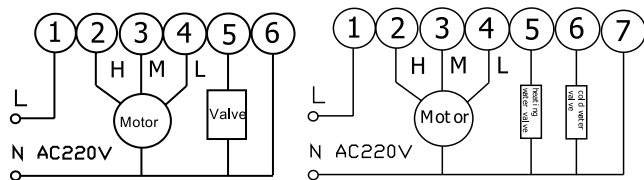

EFCT-507/507RC wiring diagram

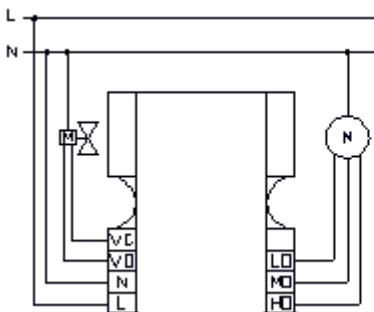

Method of controlling triple wire valve

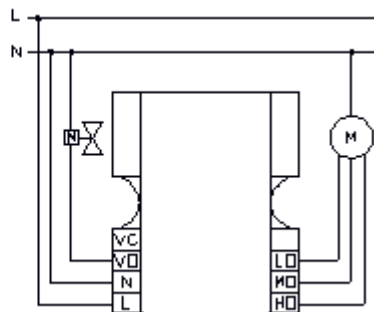

Method of controlling double wire valve

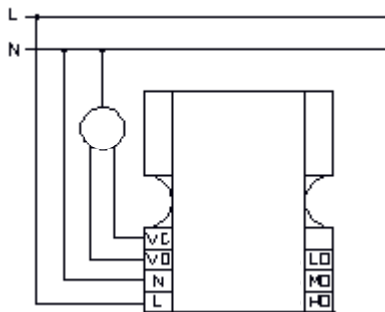

Method of quadruple pipe wiring

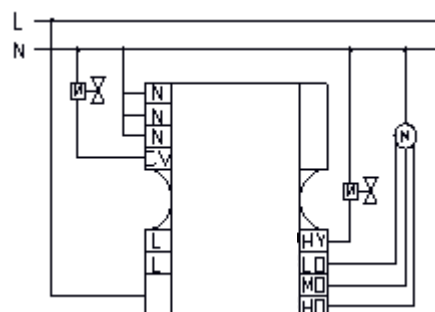

Wiring diagram of electromotion draught of thermostat

EFCT-508/508RC wiring diagram

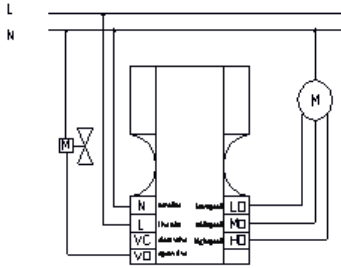

Method of controlling triple wire valve.

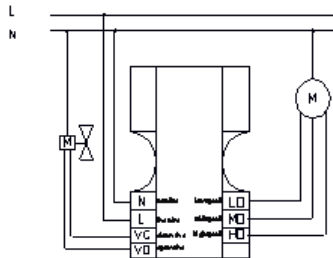

Wiring method of controlling double wire valve

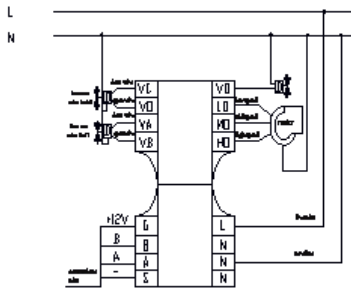

Method of quadruple pipe wiring

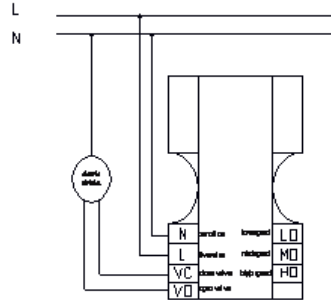

Wiring diagram of electromotion draught of thermostat

Warning: Please connect follow wiring diagram. Components may damage if water, impurity etc.enter thermostat!

EFCT-505 wiring diagram

